

# iO-FAV FRESH AIR VENTILATION INSTALLATION INSTRUCTIONS

(FOR USE WITH iO-FAV-XX, 4", 6", 7", 8", 10", 12", 14" OR 16" DAMPER)



## INTRODUCTION

The iO HVAC Controls Fresh Air Ventilation system is designed to improve residential indoor air quality. This is accomplished by introducing fresh, outside air through an intake damper controlled by a logic panel. The panel controls the amount of fresh air required each hour based on the ASHRAE 62.2 - 2013 Ventilation and Indoor Air Quality Standard.

## INSTALLATION OF INTAKE HOOD, FRESH AIR INTAKE DUCT AND MOTORIZED DAMPER

It is recommended that the intake hood be an open metal type with a screen. The fresh air intake should be located away from dryer or furnace vents, driveways, trash containers, swimming pools and at a level above any expected snow accumulation. Check all local codes that might apply. Depending on the CFM requirement, an insulated, rigid fresh air intake duct is recommended in the same diameter as the 2-wire, motorized fresh air damper provided for the application. The damper actuator is power open / spring return closed.

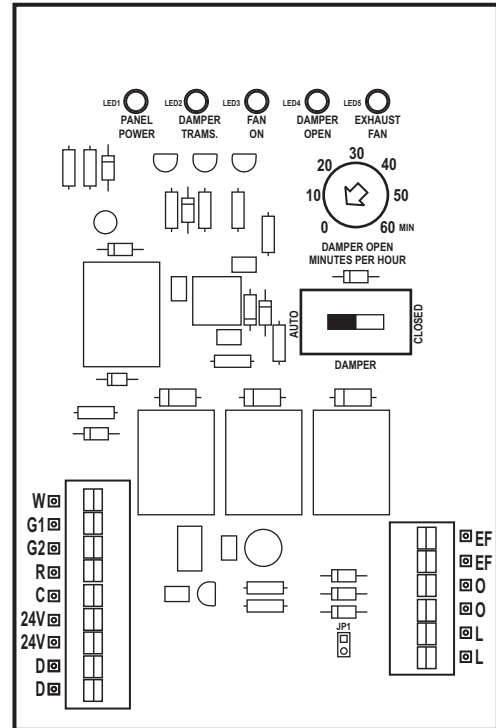

## TYPICAL BASEMENT INSTALLATION

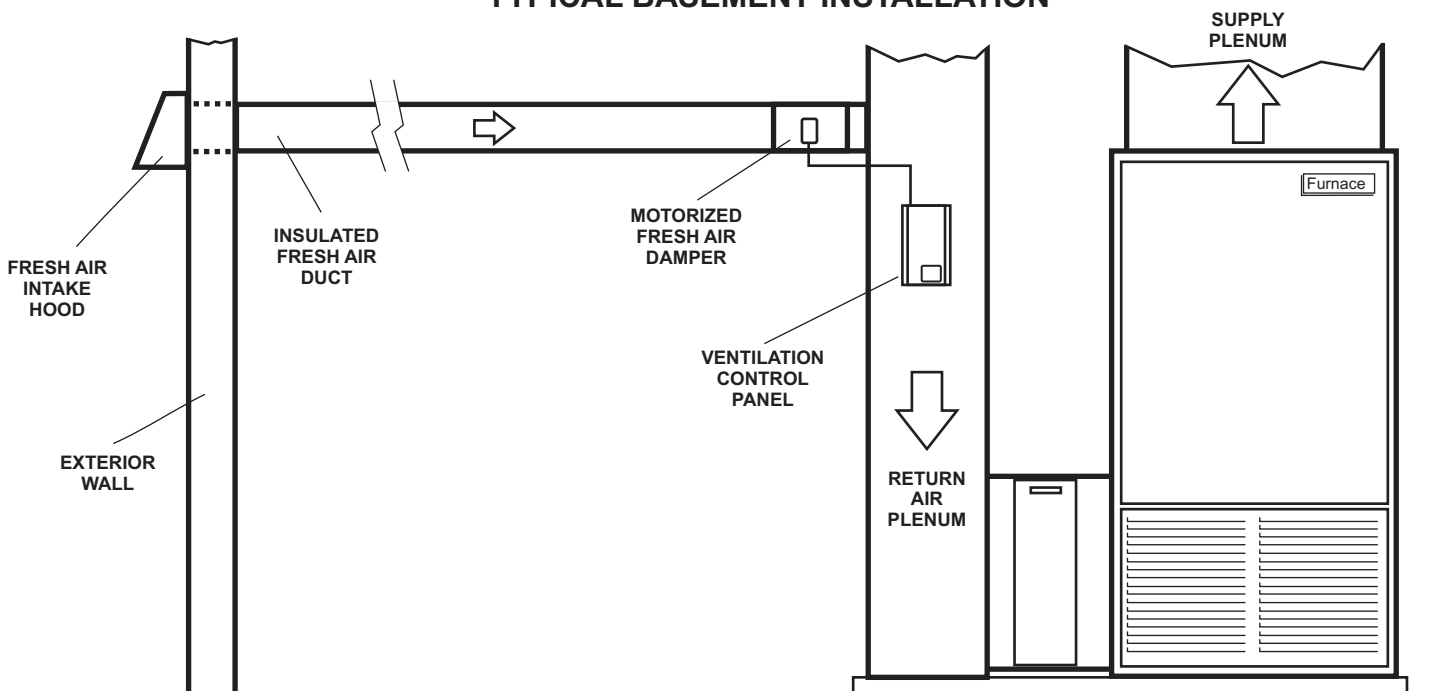

## PANEL OVERVIEW

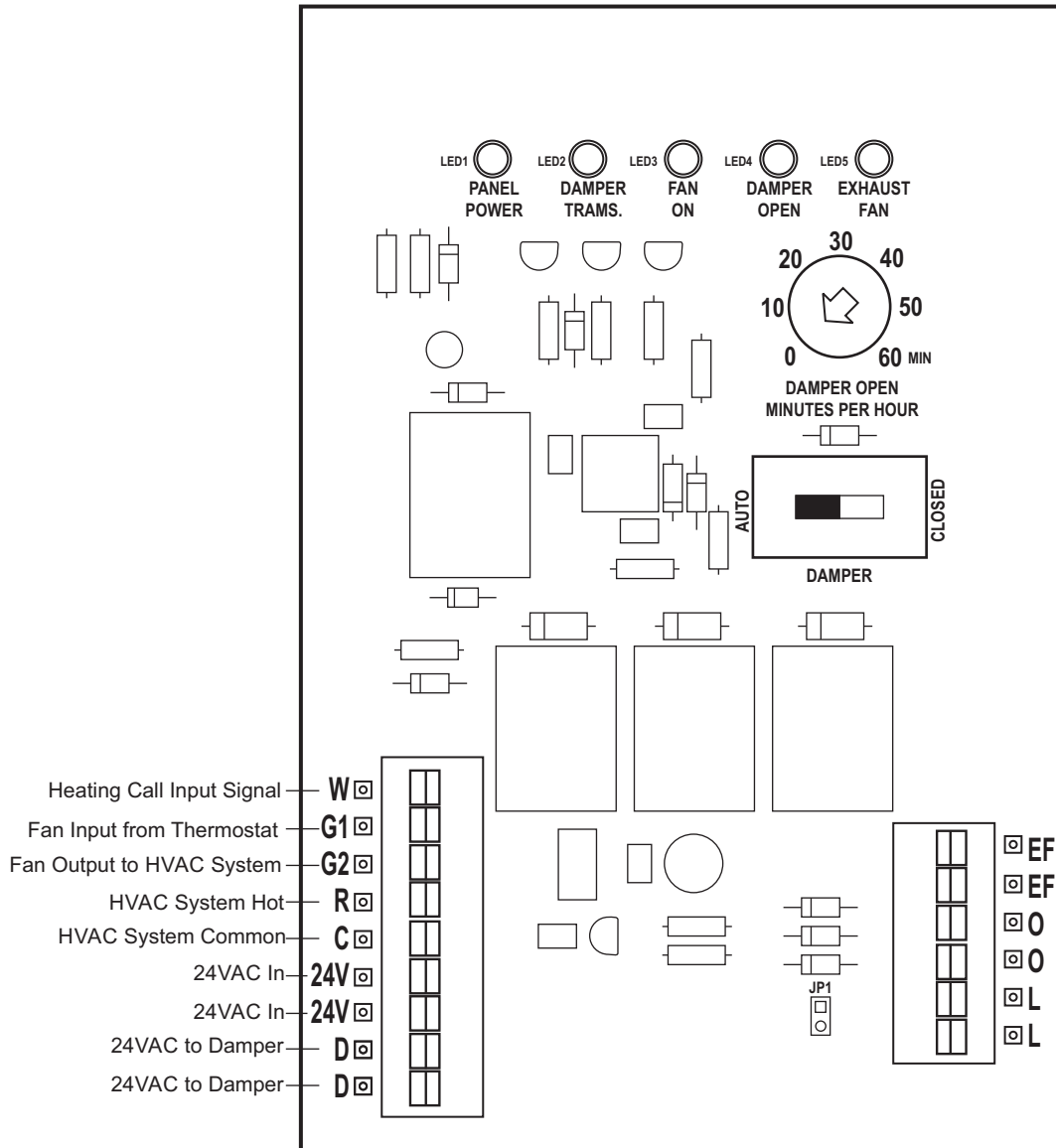

## PANEL INSTALLATION

To install the panel, remove the cover and slide the PC board out of its base. Screw the base to a flat surface in a location that allows easy access for wiring. Re-install the PC board by carefully centering it over the base and snapping it into the grooves.

The panel receives its power from the equipment transformer. A separate 24VAC, 20VA transformer is required to power the fresh air damper. Only standard 18-gauge thermostat wire is required.

### **⚠ WARNING**

Improper wiring to the HVAC unit can cause damage to the equipment and/or the panel. Disconnect electrical power before wiring the panel to the equipment.

# TYPICAL THERMOSTAT WIRING DIAGRAMS

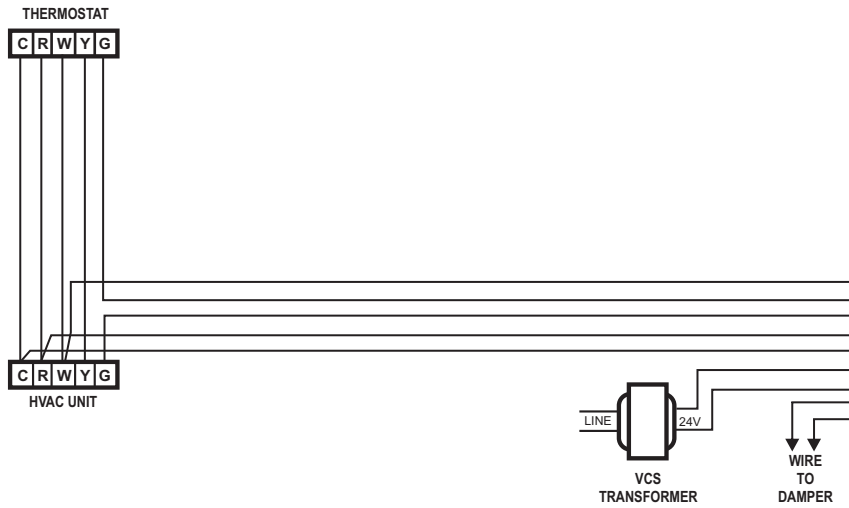

## SINGLE STAGE HEAT/COOL

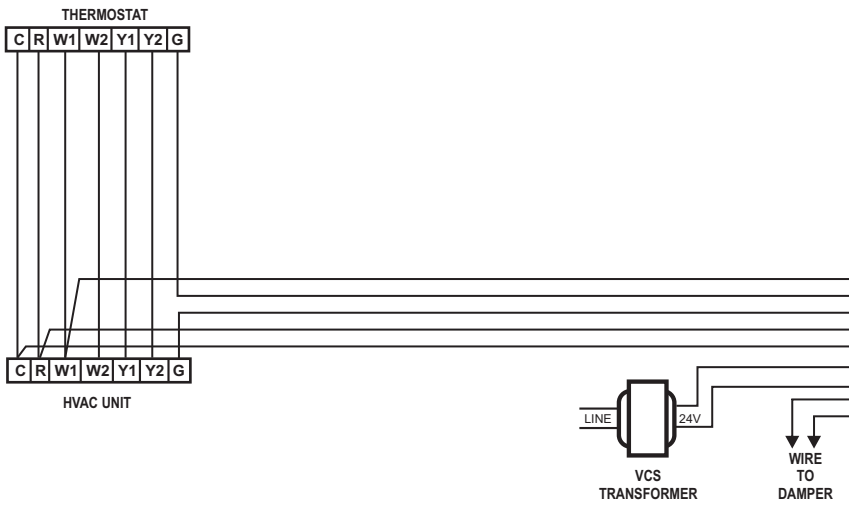
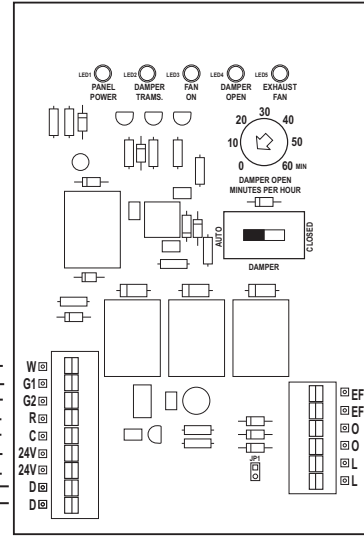

## MULTI-STAGE HEAT/COOL

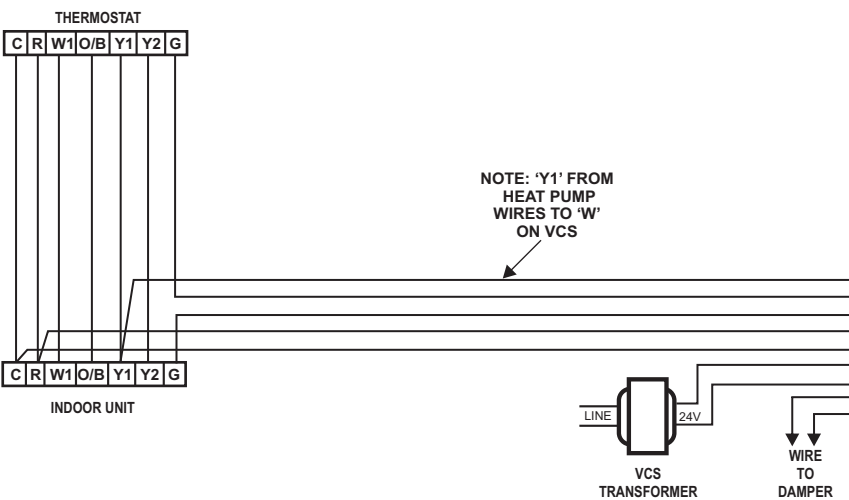
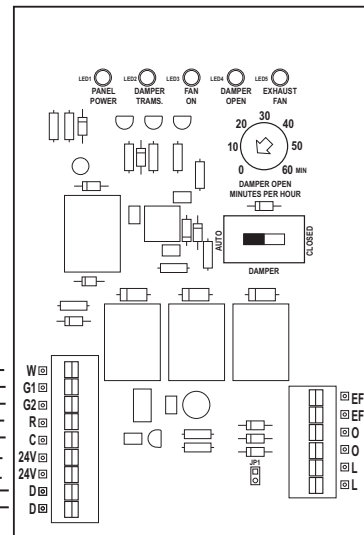

## HEAT PUMP

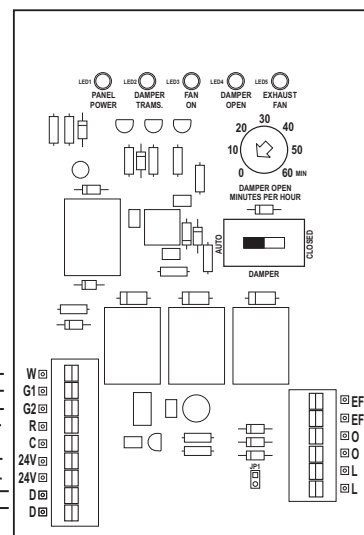

## WIRING TO OPTIONAL EXHAUST FAN

The panel can be wired to an optional exhaust fan using the 'EF' terminals located on the panel. Wire the 'EF' terminals in series with the exhaust fan relay. When the panel is in the AUTO mode, the 'EF' contacts close when the fresh air damper is opened.

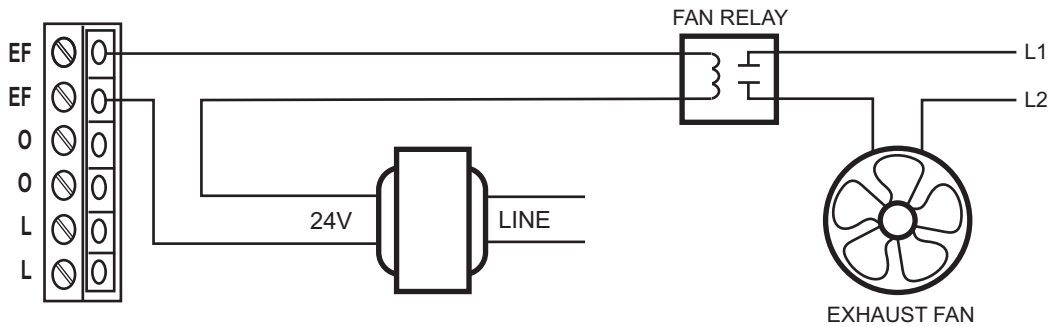

## WIRING TO OPTIONAL DAMPER OVERRIDE PERIPHERALS

The panel can be wired to an optional damper override switch, timer, current sensing relay or static pressure control used with a range hood. A dry contact closure across the 'O' terminals will open the fresh air damper and bring on the system fan. When the panel is in the damper override mode, ventilation timing and all other override inputs are ignored.

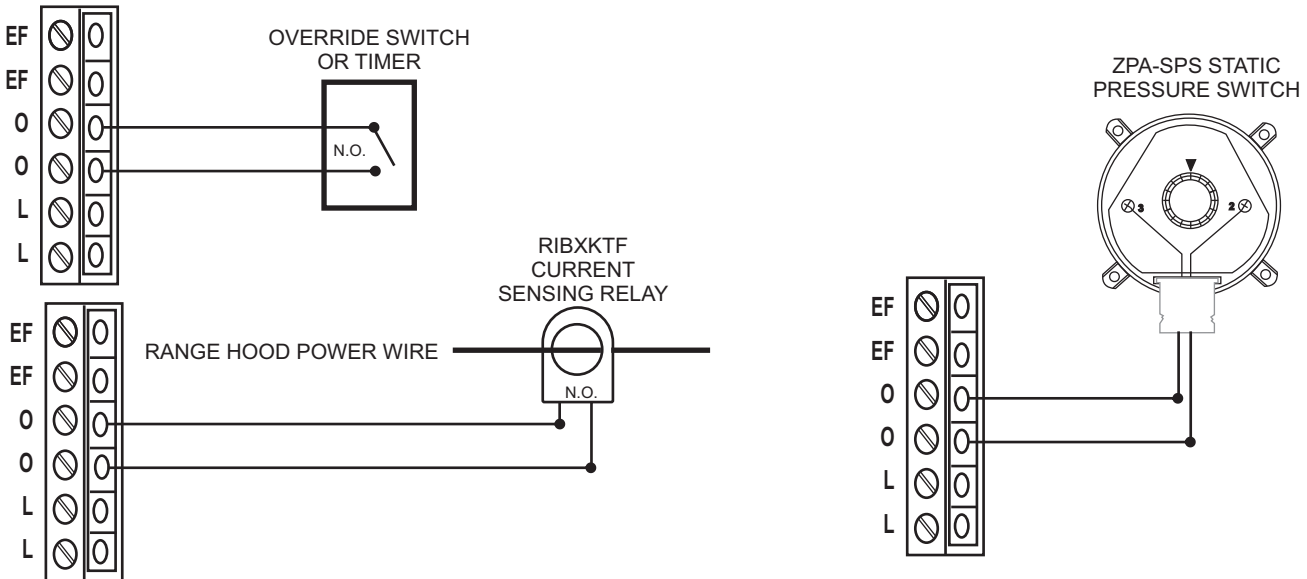

## WIRING TO OPTIONAL OUTDOOR THERMOSTAT AND/OR HUMIDISTAT

The panel can be wired to an optional outdoor thermostat and/or humidistat using the 'L' terminals to prevent the fresh air damper from opening based on a temperature and/or humidity setting. The jumper located to the left of the 'L' terminals must be removed and the outdoor thermostat and/or humidistat wired so that the contacts are closed during normal operation.

For outdoor thermostat installation:

To lockout on high temperature, connect the Blue and Red wires to the "L" terminals. (Black is not used.) To lockout on low temperature, connect the Red and Black wires to the "L" terminals. (Blue is not used)

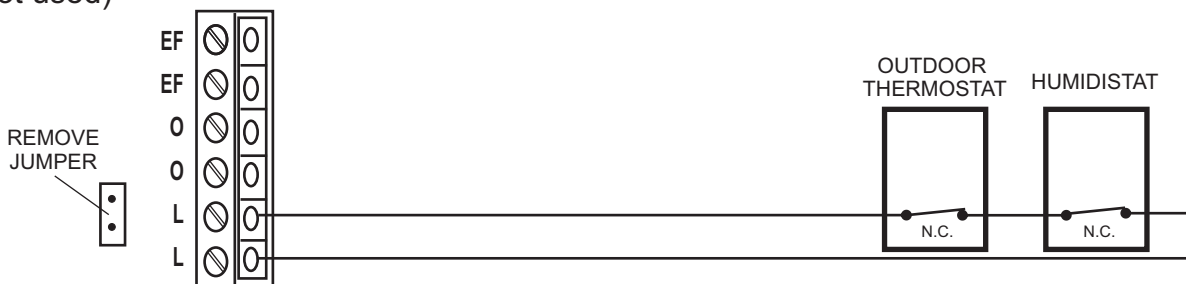

## VENTILATION TIMER QUICK REFERENCE CHART

The reference chart below is designed to provide FAV ventilation timer settings based on using 8" rigid straight duct with friction loss of 0.1" w.g. per 100 ft. This chart can be used for most applications.

VENTILATION TIMER SETTING (MINUTES PER HOUR)						
NUMBER OF BEDROOMS		ONE	TWO	THREE	FOUR	FIVE
HOME SIZE (Ft <sup>2</sup> )	<500	8	10	12	15	16
	501-1000	12	15	16	19	21
	1001-1500	16	19	21	23	25
	1501-2000	21	23	25	27	29
	2001-2500	25	27	29	31	33
	2501-3000	29	31	33	35	37
	3001-3500	33	35	37	39	41
	3501-4000	37	39	41	43	45
	4001-4500	41	43	45	47	49
	4501-5000	45	47	49	51	53

## FORMULA FOR SETTING THE VENTILATION TIMER

The FAV Ventilation Control System is designed to simplify selecting the minimum ventilation cycle rate to meet ASHRAE 62.2 - 2013 Standard by using a single dial to set the desired number of minutes per hour that ventilation will take place. The timer cycle rate is calculated as follows:

$$\text{(Home Area in Sq. Ft. x 0.03) + ((Number of Bedrooms + 1) x 7.5) = Required Airflow in CFM}$$

$$\text{(Required Airflow in CFM x 60 ÷ Total Airflow of Fresh Air Duct) x 60 = Ventilation Minutes Per Hour}$$

Example:

Home Area = 2,500 Sq. Ft. with 4 bedrooms.

$$(2,500 \times 0.03 = 75) + ((4 + 1) \times 7.5 = 37.50) = \mathbf{112.50 \text{ CFM}}$$

Total airflow of 8" rigid fresh air duct @ 0.1" w.c. = 220 CFM x 60 = **13,200 Cubic Feet Per Hour**

$$(112.50 \text{ CFM} \times 60 \text{ Minutes} = 6,750) \quad 6,750 \div 13,200 \times 60 = \mathbf{30.68 \text{ Ventilation Minutes Per Hour}}$$

The ventilation timer would be set for **31 Minutes**